

PRODUCT CODE:-

ENO-3122-P-X

CATEGORY:-

**NEMA SOCKET
(PCB Mounted)**

BASIC DIMENSIONS:-

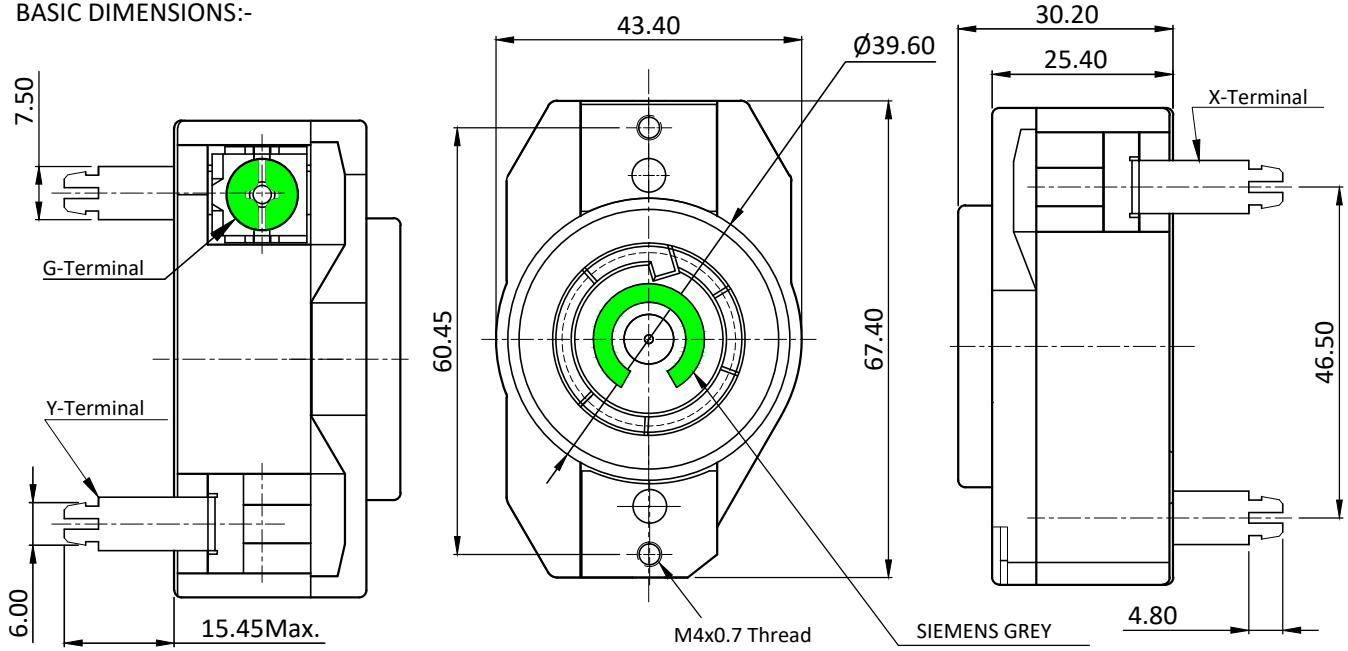

NEMA SLOT CONFIGURATION

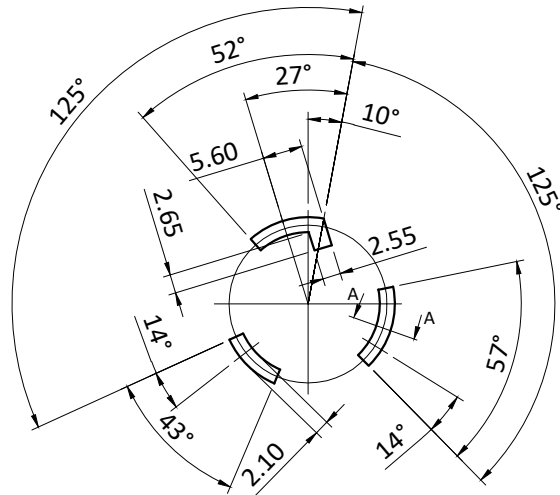
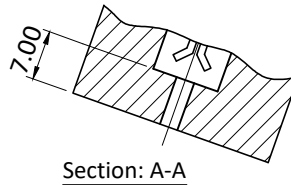

						APP	27.12.12	PBM	 <p>Plot E-4, Kagal Five Star MIDC, Kagal, Kolhapur, MH - 416236, India Elcom International Pvt. Ltd. www.elcom-in.com</p>		
						CHK	27.12.12	PGP			
						DRN	27.12.12	Vinayak			
REV	IS	WAS	DATE	SIGN	APP.	BY	DATE	SIGN			
UNSP.TOLERANCE			DIMNS. IN	WT(Gm)	SCALE:-	PROJECTION	SHEET	DRAWING NUMBER			
OVER	-	1	10	mm	Max.	NTS.	1	OF 2	P E N O 2 3 1 2 2 P		
UP TO	1	10	-	Moulding, plating details as per Bill of Material Unspecified colour is Black, GF:Glass filled.			REVISION				
±	0.2	0.3	0.5				0				

F:ENG-08.00

Note: Technical specifications are subject to change without prior notice

Copyright © 2019 by Elcom International Pvt.Ltd, India. All rights reserved

PRODUCT CODE:-

ENO-3122-P-X

CATEGORY:-

**NEMA SOCKET
(PCB Mounted)**

PANEL CUTOUT:-

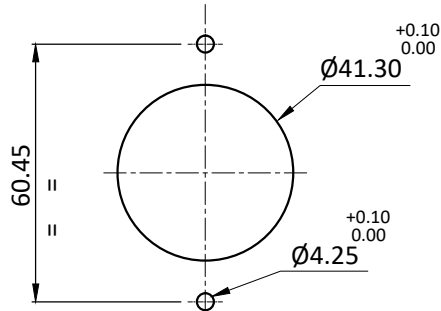

PCB Holes:-

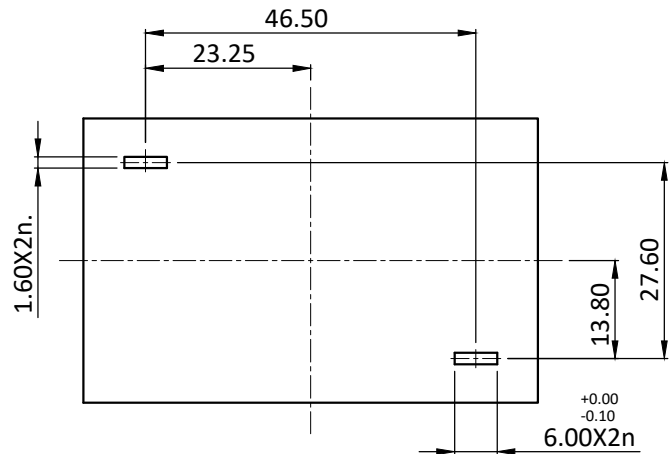

SPECIFICATION TABLE:-

SR.NO.	PARAMETER		SPECIFICATION
1	Connector Type		Twist lock L6-20R PCB Mounted type
2	V/A Rating		250 V, 20 A
3	Contact Resistance (Initial)		10 mohms max.
4	Insulation Resistance At 500 V DC		100 Mohms min.
5	H.V.Break Down Test (For 1-Minute)		2 KVAC
6	Mounting		Panel, Screw & PCB Solderable type
7	Panel Thickness		--
8	Terminals		Screw-type #14 to #10 AWG
9	Permissible Temp.	(a) With/Without Load	0°C TO 65°C
		(b) For Soldering	--
10	Material	(a) Body, Cover	Nylon-6, GF20%, V-2
		(b) Contacts, Terminals	Brass, Tin Plating
		(c) Terminal screw	Brass Tightening Torque : 12 Kg-cm min.
11	Reference Standard		UL-498, UL-486E, NEMA WD 6
12	Approvals		US, File No. E258604,

: Also available for temp. rating up to 125°C on request (For UL only)

						APP	27.12.12	PBM	Plot E-4, Kagal Five Star MIDC, Kagal, Kolhapur, MH - 416236, India Elcom International Pvt. Ltd. www.elcom-in.com
						CHK	27.12.12	PGP	
						DRN	27.12.12	Vinayak	
REV	IS	WAS	DATE	SIGN	APP.	BY	DATE	SIGN	
UNSP.TOLERANCE			DIMNS. IN	WT(Gm)	SCALE:-		PROJECTION	SHEET	DRAWING NUMBER
OVER	-	1	10	mm	Max.	NTS.		2 OF 2	P E N O 2 3 1 2 2 P
UP TO	1	10	-	Moulding, plating details as per Bill of Material Unspecified colour is Black, GF:Glass filled.					
±	0.2	0.3	0.5						0

F:ENG-08.00

Note: Technical specifications are subject to change without prior notice

Copyright © 2019 by Elcom International Pvt.Ltd, India. All rights reserved